

Opti Max2700

Optical Lid Upgrade



- **Optical lid upgrade converts legacy C-COR trunks and bridgers to nodes**
- **Economical system segmentation minimizes costs**
- **Optimized for fiber deep architectures**
- **Fiber efficient with CWDM transmitters**
- **Available as a complete low cost node with multiple outputs and redundancy**

The C-COR Opti Max2700 Optical Lid Upgrade converts a legacy FlexNet 700, 800, and Flex Max900, 901, and 901e series trunk or bridger amplifier to an optical node with one forward receiver and one return path transmitter with future upgrade options for forward and return redundancy. This lets broadband service providers create optical nodes where needed—strategically segmenting their existing Flex Max and legacy FlexNet systems without costly resplicing. The CWDM transmitters in the Opti Max2700 Optical lid upgrade offer an economical method to add nodes to your system without adding fiber. A power supply with ample headroom meets present and future needs. EMS monitoring is also an option. The lid's hot-swappable, modular design eases installation and maintenance.

Features

- Upgrade Flex Max901e, Flex Max901, Flex Max900, FlexNet 800, and FlexNet 700 series amplifiers to fiber optic nodes by replacing the lid housing
- 1 GHz bandwidth node and lid upgrade when RF module is specified to 1002MHz
- Drive fiber deeper into your HFC network
- Reduce amplifier cascades, effectively segmenting the system as needed
- Increase subscriber QoS with decreased return traffic on shortened cascades
- Eliminates resplicing costs and downtime when upgrading
- Delivers optical path redundancy with two receivers (*Available Summer 2007*)
- Supports redundant CWDM return DFB transmitter wavelengths
- Optional HMS/AM protocol Value Max transponder (*Available Summer 2007*)

Opti Max2700 Lid Upgrade—RF Module and Optical Lid Functional Block Diagrams

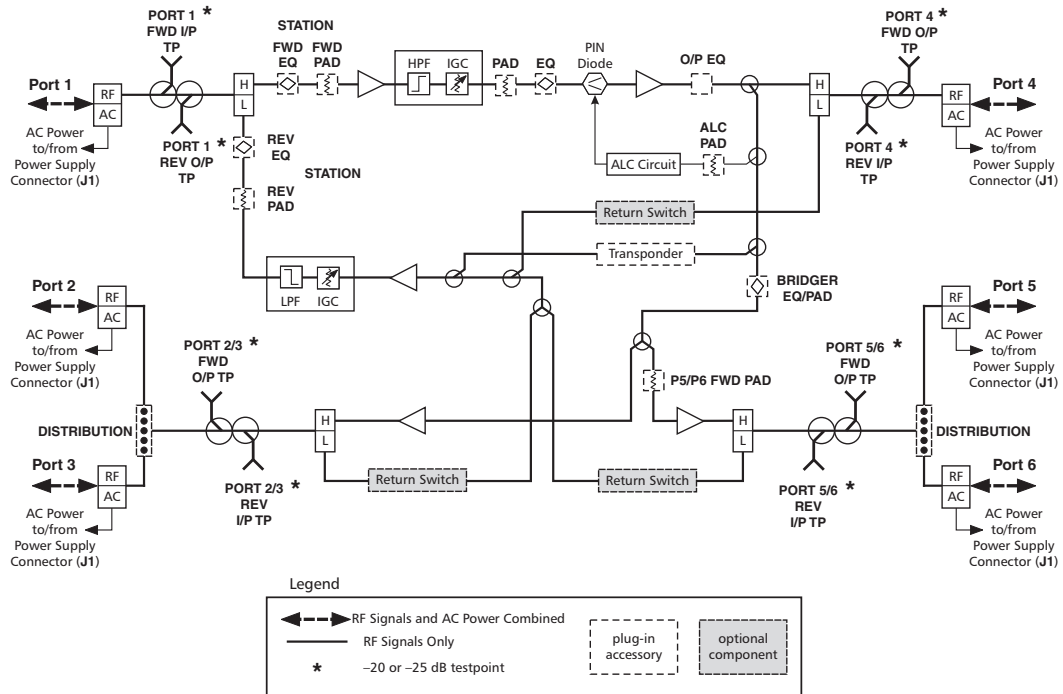

901e Series Trunk Amplifier

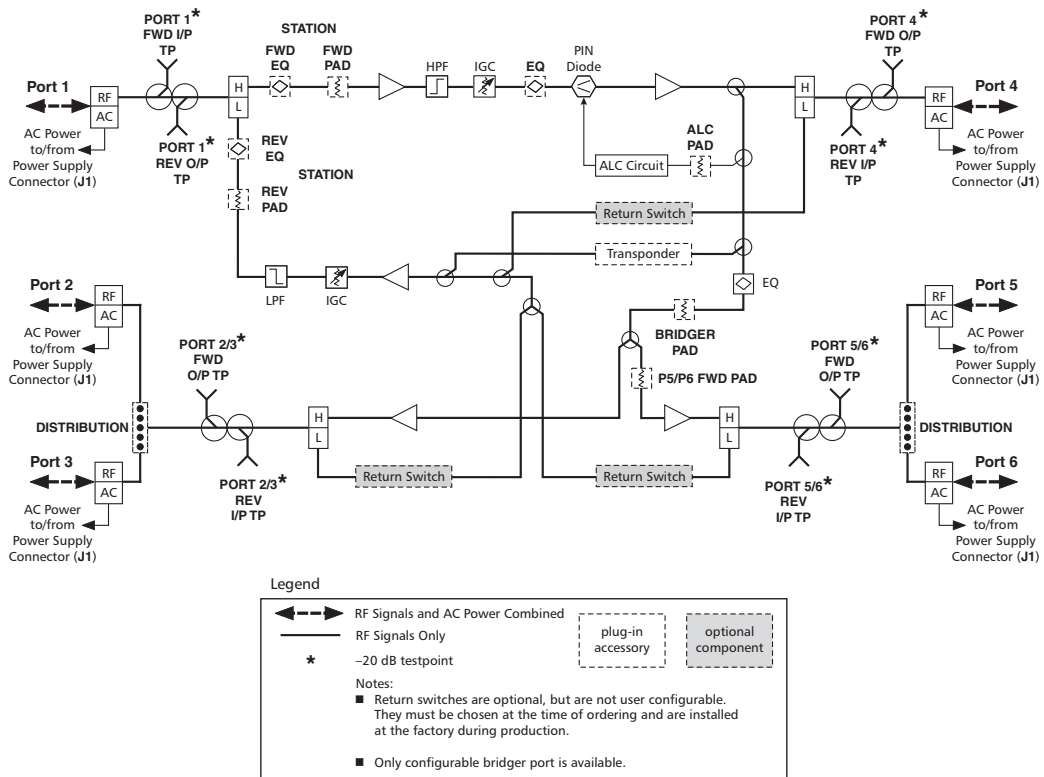

901 Series Trunk Amplifier

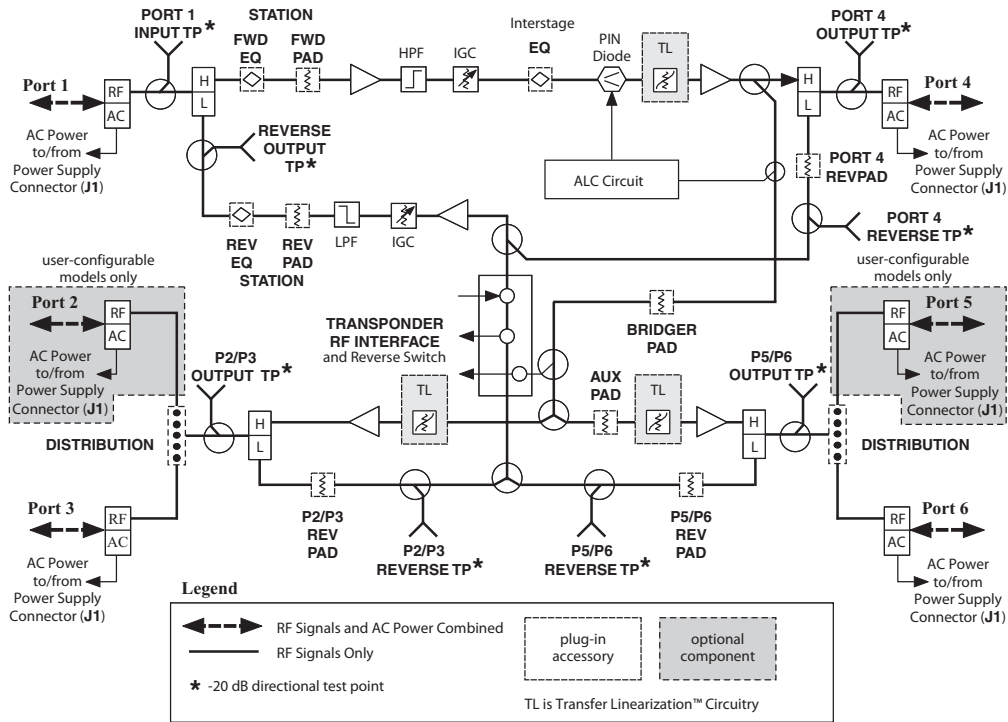

900 Series Trunk Amplifier

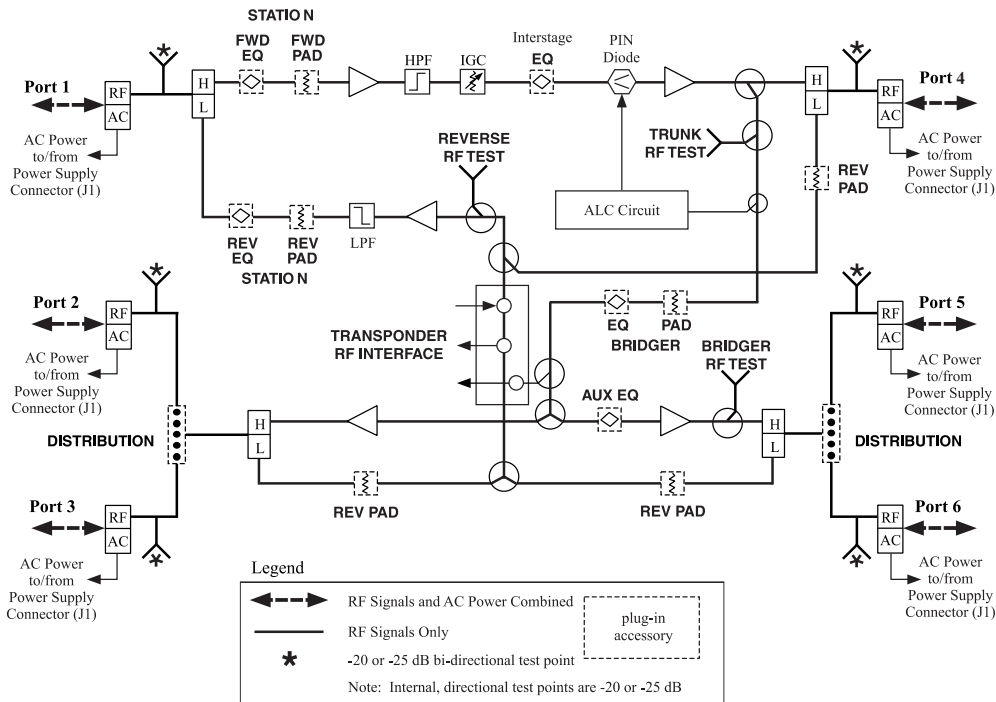

800 Series Trunk Amplifier

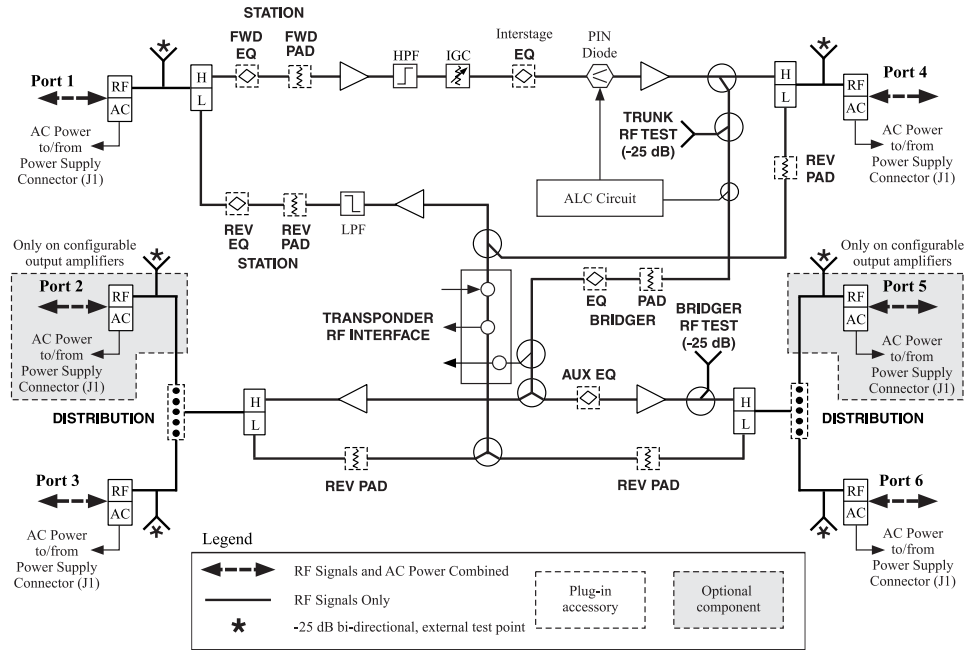

700 Series Trunk Amplifier

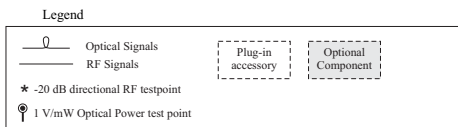
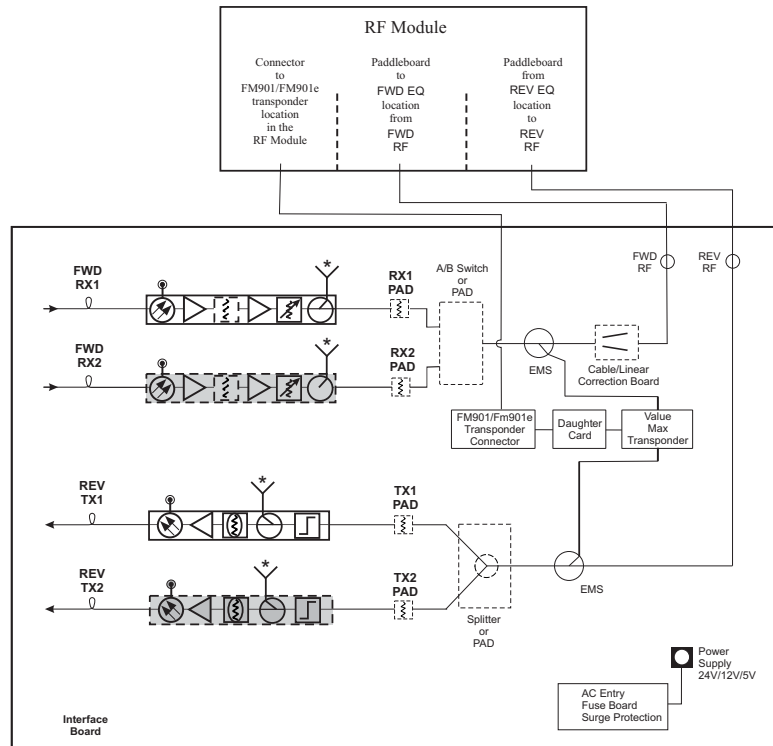

Opti Max2700 Optical Lid

Opti Max2700 Optical Lid Specifications

General Optical Lid Parameters

Temperature range	-40 to 60°C			
DC Powering Requirements (Note 1)				
Current draw	24V Line	12V Line	5V Line	Total Power (W)
Non-redundant CWDM Return	100	545	685	12.37
Non-redundant CWDM Return, with EMS	142	545	705	13.47
Redundant CWDM Return	200	1090	1370	24.73
Redundant CWDM Return, with EMS	242	1090	1390	25.84

Forward Path Characteristics

Wavelength nm	1290–1600
Optical Input Power, dBm (Note 2)	-3.0 to +3.0
Optical Input Power Testpoint, V/mW	1.0
LED Indicators	
DC Power	Green: DC power OK; Off: Power not available
Optical Power Threshold	Green: Above threshold; Off: Below threshold
RX On/Off	Green: Receiver on; Off: Receiver remotely turned off
Equivalent Input Noise, pA/Hz 0.5 max (Note 3)	5
Frequency, MHz	1002/870/550/54
Lid Output Levels (Note 4)	20/20/20/20
Frequency Flatness, dB (Note 5)	±0.5
Level Stability, dB (Note 6)	±1.0
Carrier to Noise Ratio, 4MHz, 75Ω, dB (Notes 4, 7, 8,)	60
Composite Triple Beat, -dBc (Notes 7, 8)	83
Cross Modulation, per NCTA std., -dB (Notes 7, 8)	80
Composite 2IM, -dBc (Notes 7, 8)	69
Composite Intermodulation Noise, dB (Notes 7, 8)	82

Return Path Characteristics

Optical Power, dBm (Note 9)	3.0 ± 1.0
Transmitted Wavelength	1310 ±20, 1550 ±20 or CWDM Channel ±6.5
LED Indicators	
DC Power	Green: DC power OK Off: Power not available
Optical Power Threshold	Green: Output ≥ 1.5mW Off: Output < 1.5mW
RF Passband, MHz	5 to 200
Frequency Flatness, dB (Note 10)	±0.5
Level Stability, dB (Note 11)	±1.0
NPR/Dynamic Range, dB (Note 12)	35/15
NPR Peak, typical, dB (Note 12)	45
BER Dynamic Range	
QPSK @ 1E-6 dB	45
QAM - 16 @ 1E-6 dB	30

Specification Document Number 1503069 Rev B

Notes:

- For AC current draw and power supply power plots see documents 333995-36 and 1503093.
- Circuit resiliency to +5 dBm.
- EIN performance at 5 pA/Hz0.5 is to 550 MHz only. From 550 MHz to 1002 MHz degrades to 7 pA/Hz0.5.
- Measured at 0dBm received and 3.5% OMI.
- Forward receiver specification full node ±2.0dB flatness.
- Forward receiver specification node level stability ±1.5 dB.
- The distortion values listed represent the optical lid only, to calculate full link specs, one must combine the forward path transmitter specs, the optical lid and RF amplifier specifications.
- 79ch NTSC, 75channels of 256QAM operating at -6dBc. 256QAM loading from 555-999MHz.
- Measured at the output of the bulkhead connector.
- Reverse node specification ±1.5 dB flatness.
- Node specification.
- All NPR performance specifications are measured over a 6dB (pure glass) fiber link using 35 MHz PRN loading with an optical receiver causing little to no degradation to performance.

Specifications subject to change without notice

Powering Information

AC Input Current

Voltage	AC Input Current (Amps) ^{1,2}										
	90	85	80	75	70	65	60	55	50	45	40
Maximum Load³	1.28	1.35	1.43	1.52	1.63	1.77	1.93	2.14	2.40	2.77	3.30
2 TX and 2 RX											
2.0A	0.98	1.02	1.07	1.13	1.20	1.30	1.41	1.55	1.73	1.97	2.29
1.8A	0.91	0.95	1.00	1.06	1.12	1.20	1.31	1.44	1.60	1.82	2.11
1.6A	0.87	0.90	0.94	0.99	1.05	1.12	1.21	1.33	1.48	1.66	1.93
1 TX and 1 RX											
2.0A	0.85	0.88	0.92	0.97	1.03	1.10	1.19	1.30	1.45	1.64	1.90
1.8A	0.80	0.82	0.86	0.90	0.95	1.01	1.09	1.19	1.32	1.49	1.72
1.6A	0.74	0.77	0.79	0.83	0.87	0.93	1.00	1.09	1.20	1.35	1.56

1. A single transmitter and receiver draw approximately 100mA at 24V; dual transmitters and receivers draw approximately 200mA at 24V. In each configuration, the RF module current draw must be added to the values in this table for accurate results. Refer to the specification sheet for your specific RF module(s) for more information.
2. Test data was conducted using C-COR standard efficiency test (334010 Rev C).
3. Maximum load = 2.3A on 24V line, 2.0A on 12V line, and 2.0A on 5V line.

AC Input Power

Voltage	AC Input Power (Amps) ^{1,2}										
	90	85	80	75	70	65	60	55	50	45	40
Maximum Load³	107	107	107	107	107	107	108	108	109	110	112
2 TX and 2 RX											
2.0A	79	79	79	79	79	79	79	79	80	80	81
1.8A	74	74	74	73	73	73	74	74	74	74	75
1.6A	69	68	68	68	68	68	68	68	68	69	69
1 TX and 1 RX											
2.0A	67	67	67	67	67	67	67	67	67	67	68
1.8A	62	62	61	61	61	61	61	61	61	62	62
1.6A	56	56	56	56	56	56	56	56	56	56	57

1. A single transmitter and receiver draw approximately 100mA at 24V; dual transmitters and receivers draw approximately 200mA at 24V. In each configuration, the RF module current draw must be added to the values in this table for accurate results. Refer to the specification sheet for your specific RF module(s) for more information.
2. Test data was conducted using C-COR standard efficiency test (334010 Rev C).
3. Maximum load = 2.3A on 24V line, 2.0A on 12V line, and 2.0A on 5V line.

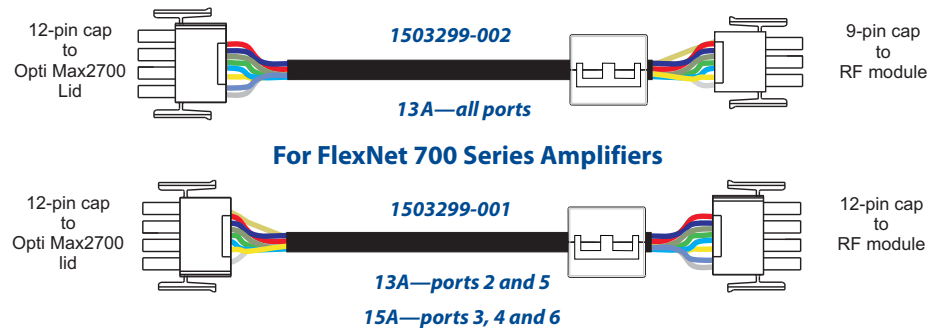

For FlexNet 800 and Flex Max900/901/901e Series Amplifiers

Opti Max2700 Upgrade Power Supply Cables with Ferrite

Opti Max2700 Forward Receiver Specifications

Characteristic	Specification
Optical Specifications	
Optical Wavelength, nm	1290 to 1600
Optical Input Return Loss, dB, min.	45
Equivalent Noise Input, pA/Hz ^{0.5} ¹	5.0
Optical Input Range, dBm ²	-3 to 3
Optical Power Threshold Alarm Limits, dBm	User-settable: -10 to 0
RF Specifications	
Impedance, Ohms	75
Frequency Range, MHz	40 to 1002
Slope, dB	± 0.5
Flatness, dB ³	± 0.5
Return Loss, dB min.	16.0
RF Output Level, dBmV, min. ⁴	20.0
Thermal Stability, dB ⁵	± 1.0
Testpoint Specifications	
Output RF Testpoint, dB	-20 ± 1.0
Optical Power Monitor	1V/mW ± 10%
Optical Threshold Testpoint	1V/mW
79 NTSC Channel Performance Specifications @ Recommended Levels, typ.^{6,7}	
Frequency, MHz	1002/870/550/54
Output Level, dBmV	20/20/20/20
Carrier to Noise Ratio, 4MHz, 75 Ohm, dB	60
Composite Triple Beat, -dBc	83
Cross Modulation, per NCTA std., -dB	80
Composite 2IM, -dBc	69
Composite Intermodulation Noise CIN, dB ⁶	82
LED Indicators	
On/Off	Green: RF output on Off: RF output off
Optical Power Threshold	Green: optical input above threshold Off: optical input below threshold
DC Power	Green: DC power okay Off: DC power failure
Powering Requirements	
Supply Voltages, VDC	24/12/5
DC Current, mA, max.	510/<5
5Volt Line	550
12Volt Line	10
24Volt Line	300
Power Consumption, W, max.	12.25
5Volt Line	2.75
12 Volt Line	.120
24 Volt Line	.007

Opti Max2700 Forward Receiver Specifications (cont'd)

Characteristic	Specification
Environmental Specifications	
Operating Temperature, °C ⁴	-20 to 85
Storage Temperature, °C	-40 to 85
Relative Operating Humidity, %, noncondensing	95
Gain Control	
Plug-in PADs	NPB-110

Specification Document Number 1503109 Rev B

1. EIN performance at 5 pA/Hz0.5 is to 550 MHz only. From 550 MHz to 1002 MHz degrades to 7 pA/Hz0.5.
2. Circuit resiliency to +5dBm.9
3. Flatness is measured with respect to slope.
4. RF output level is 20 dBmV minimum @ 1002 MHz with a -3.0 dBm received power, transmitter OMI of 3.5%.
5. The receiver module is designed to operate in a node application with external ambient temperature ranging from -40 to 60° C.
6. The distortion values listed are for the receiver only. To obtain a particular link performance, combine the listed receiver performance values with the applicable transmitter performance values.
7. Systems operating with digitally compressed channels or equivalent broadband noise from 550 to 1002 MHz at levels 6 dB below equivalent video channels will experience a composite distortion (CIN) appearing as noise in the 54 to 550 MHz frequency spectrum. Distortions are typical with an input of 0 dBm @ 3.5% OMI.

Opti Max2700 CWDM Analog Return Transmitter Specifications

Optical Specifications	
Output Power, dBm ¹	3 ± 1
Transmitted Wavelength, nm	CWDM Channel ±6.5
Laser Type	Isolated Uncooled DFB
Optical Power Voltage Testpoint	1 V/mW ± 10%
Optical Connector Types	SC/APC, FC/APC, SC/UPC, FC/UPC
LED Indicators	
Optical Power	Green: ≥1.5 mW output; Off: <1.5 mW output
DC Power	Green: DC Power OK; Off: DC power not available
RF Specifications	
Impedance, Ohms	75
RF Bandpass, MHz	5 to 200
Return Loss, dB	-16
RF Testpoint Insertion Loss, dB ²	20 ± 0.5
Flatness, dB, max. ³	±0.5
Gain Slope, dB, max. ⁴	±0.5
Level Stability Over Temp., dB	±2.5
Reverse Spurious, -dBc	<60
Operating Temperature, °C ⁵	-30 to 85
Powering Specifications	
Supply Voltage, VDC	24/12/5 ± 0.5
Current Draw, mA, max.	60/540/5

Opti Max2700 CWDM Analog Return Transmitter Specifications (cont'd)

Performance⁶

Optimum Transmitter Input Level, dBmV/6MHz	27 dBmV/6MHz (-56 dBmV/Hz)
Optimum RF Testpoint Level, dBmV/6MHz (-20dB)	27 dBmV/6MHz (-56 dBmV/Hz)
NPR/Dynamic Range, dB ^{7,8}	35/15
NPR Peak, dB ⁸	45
BER Dynamic Range, dB	
QPSK@1E-6	45
QAM -16 @1E-6	30
EMS Monitor Status (Laser Shut Down)	
Enabled, V	0 ± 0.25
Disable, V	5 ± 0.25

Specification Document Number 1503013 Rev A

1. Measured at output of bulkhead connector.
2. RF monitor point is -20dB referenced to the transmitter input and accurate from 5 to 100MHz.
3. Flatness is measured with respect to gain slope.
4. Gain slope is measured as a straight line from 5 to 200MHz.
5. Denotes transmitter temperature. Product must operate in a node from -40 to 60°C.
6. All performance specifications measured while installed in an Product Name (short) node with an optical receiver causing low degradation to performance (~0.5 dB).
7. Measured over 6dB fiber link using 35 MHz PRN loading.
8. Typical NPR performance measurements taken at room temperature.

**Opti Max2700 CWDM Analog Return Transmitter, NPR and 16-QAM BER
25 km (~6 dB) Fiber Link**

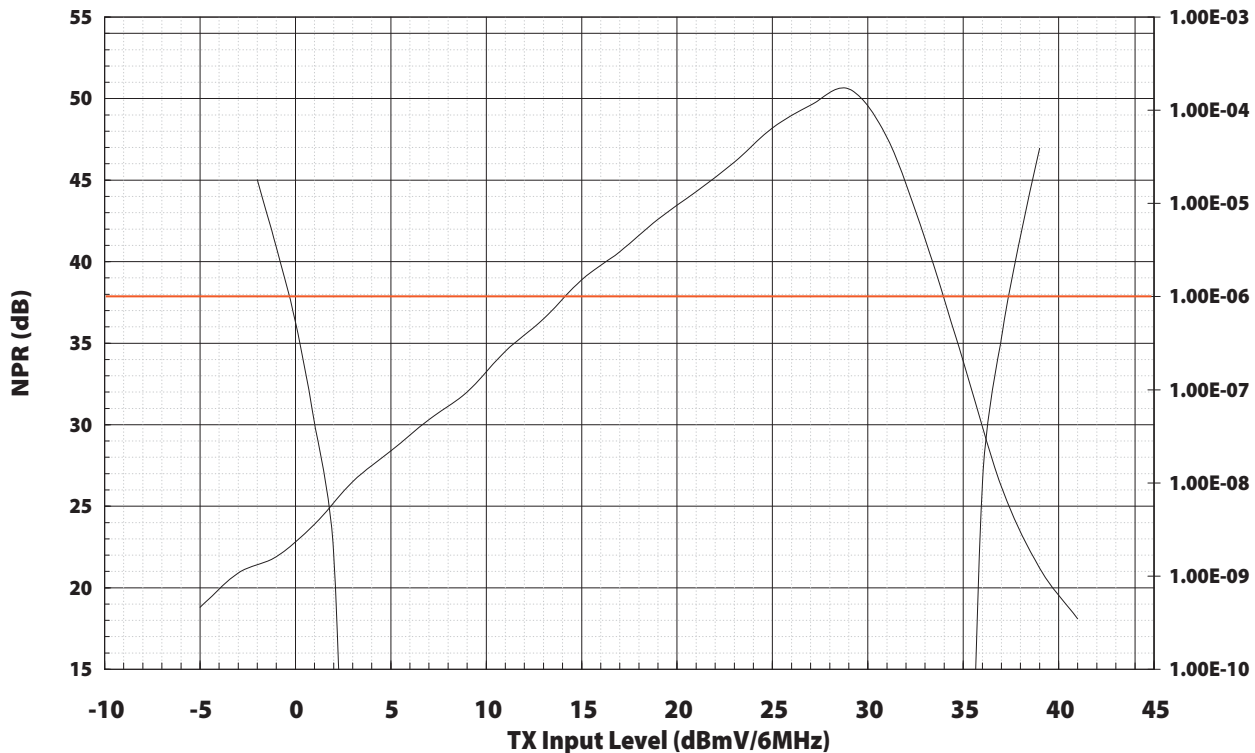

Ordering Information

1	2	3	4	5	6	7	8	9	10	11	12	13	14	15	16	17	18	19	20	21	22	23	24			
O	M	2	7	x	x	U	P	-	G	R	A	D	x	O	x	-	x	x	1	x	x	x	1	-	O	O

1-4 Platform	Opti Max2700
---------------------	--------------

5-6 Series	7A Upgrade Lid, FlexNet 700 Series T/B, 750MHz, 11 dB Cable Loss 8A Upgrade Lid, FlexNet 800 Series, T/B, 750MHz, 12dB Cable Loss 8B Upgrade Lid, FlexNet 800 Series, T/B 870MHz, 12dB Cable Loss 9A Upgrade Lid, FlexNet 900 Series, T/B, 750MHz, 11 dB Cable Loss 9B Upgrade Lid, Flex Max900 Series, T/B, 750MHz, 17dB Cable Loss 9C Upgrade Lid, Flex Max900 Series, T/B, 870MHz 18dB Cable Loss EB Upgrade Lid, Flex Max901/901e Series, Brdgr, 1GHz, 23 dB, Cable Loss ET Upgrade Lid, Flex Max901/901e Series, Trnk, 1GHz, 13dB Cable Loss
-------------------	--

7 Spacing	U None	a
------------------	--------	---

8 Frequency Split	P None	a
--------------------------	--------	---

9-10 Level Control	GR None	a
---------------------------	---------	---

11 Return	A None	a
------------------	--------	---

12 Output Configuration	D None	a
--------------------------------	--------	---

13 Powering and External Surge Protection	E 90V High Efficiency Power Supply	a
	1 90V High Efficiency Power Supply with External Surge Protection Circuit	a
a) 100W.		

14 Housing	0 None	a
a) Select "1" in #15 block, Housing Finish . Required when ordering module only.		

15 Housing Finish	1 Standard	a
	4 Corrosion protected	
a) Required when ordering module only.		

16 Forward Receiver	0 None	a
	A Single receiver	
a) Must select "A" in #18 block, Forward RX Connector .		

17 Forward Receiver Connector	A None	a
	B FC/APC	
	C SC/APC	
	D FC/UPC	
	E SC/UPC	
a) Must select "0" in #17 block, Forward Receiver .		

18 Forward Configuration	1 Non-redundant (Single receiver)
---------------------------------	-----------------------------------

19-20 Return Transmitter	00 None	a
	0x Select 1 transmitter wavelength from the list below	
	xx Select 2 transmitter wavelengths from the list below	
Return Transmitter Wavelength (please specify)		
	L 1471 nm CWDM Transmitter	
	M 1491 nm CWDM Transmitter	
a) Must select "A" in #2 block, Return Transmitter Connector .		

21 Return Transmitter Connector	A None	a
	B FC/APC	
	C SC/APC	
	D FC/UPC	
	E SC/UPC	
a) Must select "00" in #19-20 block, Return Transmitter .		

22 Return Configuration	1 Non-redundant (Single transmitter)
--------------------------------	--------------------------------------

23 Status Monitoring	0 None	a
b) Select "7" in #11 block, Return . This is a frequency-agile transponder.		

24 Future Option	0 None
-------------------------	--------

Opti Max2700 Lid Upgrade Identification

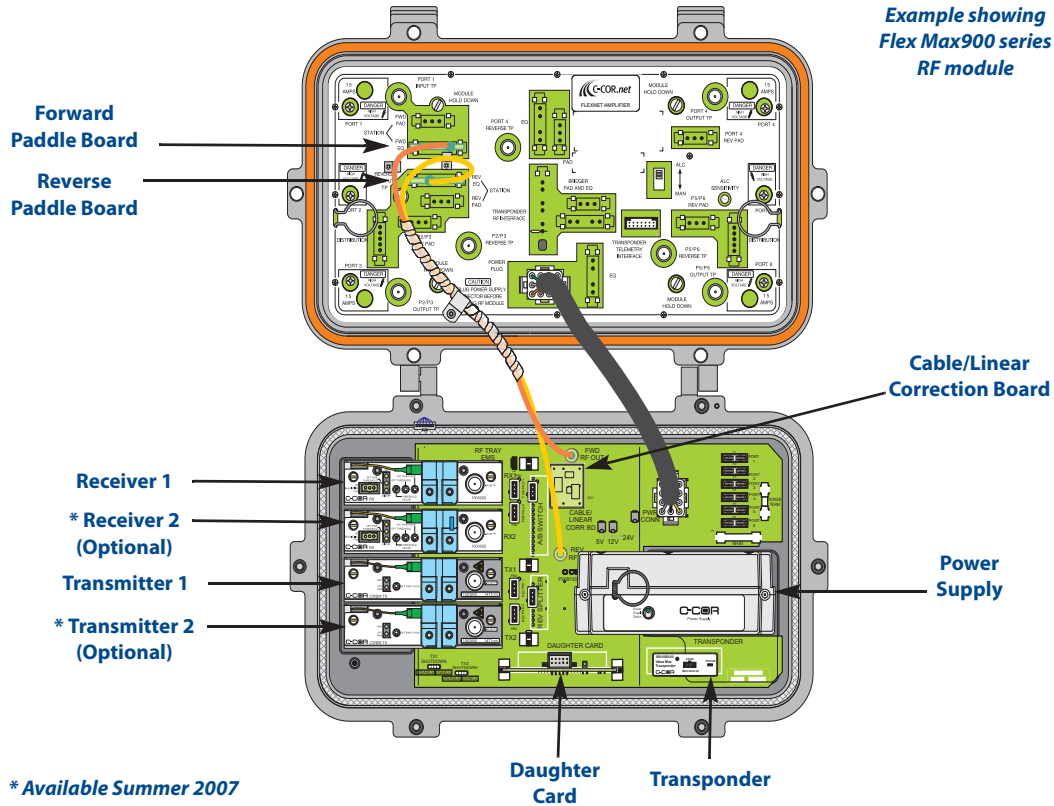

Opti Max2700 Lid Upgrade—Factory-Shipped Accessories

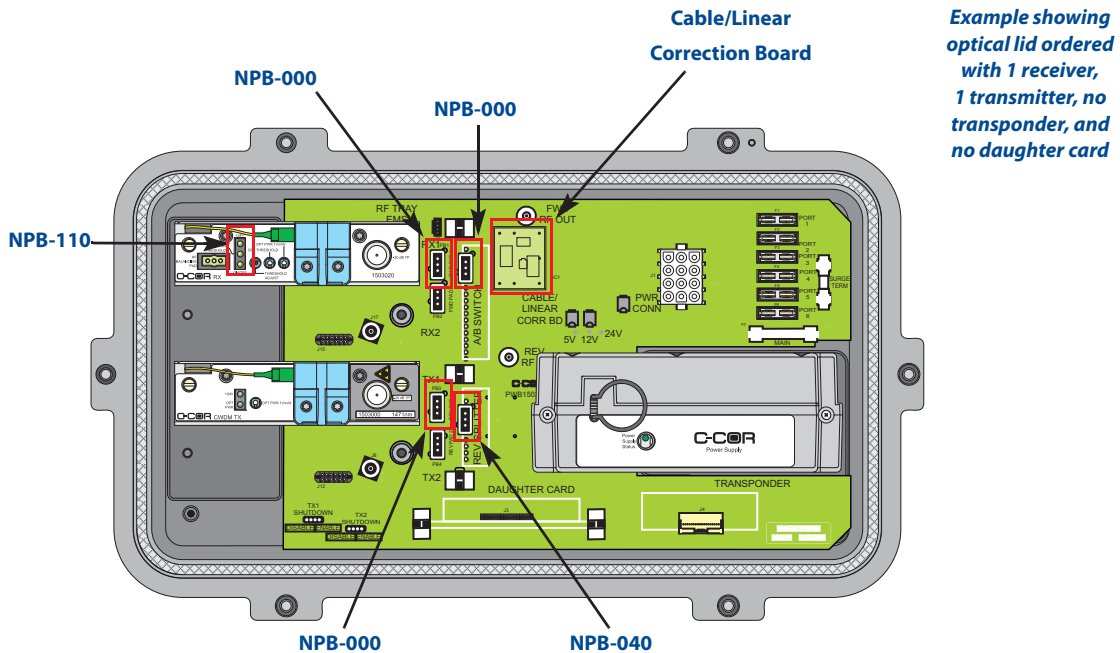

Optical Lid Accessory Reference

Description	Part Number	Specification Number
Forward Receiver	1503020-00x	1503109
CWDM Isolated DFB Transmitter	150300x-00x	1503013
Powering Accessories		
Power Supply	1502869-001	1503093
10" Power Supply Cable; 9-pin to 12-pin; 700 Series	1503299-002	N/A
OR		
10" Power Supply Cable; 12-pin to 12-pin; 800, 900, 901, 901e Series	1503299-001	N/A
Surge Terminator	1500390-003	N/A
3 AG 6.25A 250V Slow Blow Fuse	FG0010	N/A
Fuse/Screw Kit (1 kit included with each lid)	1503110-001	N/A
6 Auto Blade 30A Fuses	FG0032	N/A
2 6-32 x 3/8 Philips Pan Head SMS	HS0010	N/A
1 Paddle Board Nylon Cable Clamp	1503189	N/A
NPB PADS	NPB-000 through NPB-020	601263
Cable/Linear Correction Board (appropriate board per configuration)		
901/901e Series Trunk CLCB—13 dB Cable 1 GHz	1503185-005	N/A
901/901e Series Bridger CLCB—23 dB Cable 1 GHz	1503185-006	N/A
900 Series CLCB—18 dB Cable 870MHz	1503185-001	N/A
700 Series CLCB—11 dB Cable 750MHz	1503185-002	N/A
800 Series CLCB—12 dB Cable 750MHz	1503185-003	N/A
800 Series CLCB—12 dB Cable 870MHz	1503185-004	N/A
900 Series CLCB—17 dB Cable 750MHz	1503185-007	N/A
900 Series CLCB—11 dB Cable 750MHz	Use 1503185-002	N/A
Hinge Pin Extraction Tool	MX0783	N/A

Opti Max2700 Optical Lid Physical Specifications

Characteristic	Measurement
Height	10.3 inches (26.2cm)
Width	16.0 inches (40.6cm)
Depth	5.9 inches (15.0cm)
Weight (uncrated)	12 pounds (5.5kg)

1. Approximate weight for a fully-configured lid built with 1 forward receiver, 1 return transmitter, one power supply, a transponder, and appropriate accessories.

Americas Headquarters

60 Decibel Road • State College • Pennsylvania • 16801 • USA
 T: 1-814-238-2461 T: 1-800-233-2267 F: 1-814-238-4065

EuroPacific Headquarters

Transistorstraat 44-V • 1322 CG Almere • The Netherlands
 T: 31-36-546 1111 F: 31-36-536 4255

Flex Max is a trademark and the C-COR logo is a registered trademark of C-COR Incorporated.
 Copyright © 2007 C-COR Incorporated. All rights reserved.



www.c-cor.com

