

Flex Max222

Basic

Distribution Amplifier



Applications

- **Distribution amplifier or tap driver**
- **High gain amplifier for fiber deep architectures**
- **Medium and large multi-dwelling unit architectures**

The C-COR Flex Max222 Basic Distribution Amplifier combines advanced RF technology and installer friendly features with a 2-output design to deliver signals to the subscriber at lower expense. The Flex Max222 Basic Amplifier is dedicated to systems in which input sources are cable drops.

The Flex Max222 Basic Amplifier is an advanced distribution amplifier to meet the requirements for modern HFC multi-transport networks. Applied robust Gallium Arsenide technology improves system performance and drives total system costs down. The Flex Max222 Basic has a convenient input equalizer built onto the motherboard, enabling the equalization value to be achieved with attenuators. This enables operators to carry only one type of plug-in accessory and, thus, drastically reduce operational expenses. The on-board interstage equalizer has jumper-selectable 0, 8, or 13dB tilt options, and the on-board interstage attenuator has jumper-selectable 0 or 6dB options. With the availability of both 37dB standard gain and 41dB high gain models, the Flex Max222 Basic covers all applications for modern high performance distribution amplifiers.

Features

- 2-output multi-purpose amplifier with GaAs hybrid
- High level power doubler output with either 37dB standard gain or 41dB high gain
- Input equalizer and attenuator set in 1 dB steps with Amini plug-ins
- Jumper-selectable interstage attenuator with 0/6dB options
- Jumper-selectable interstage equalizer with 0/8/13 dB tilt options
- Optional splitter or 8dB and 12dB TAPs (directional couplers) to provide two RF outputs
- Available with up to 6A power passing

Flex Max222 Basic Distribution Amplifier

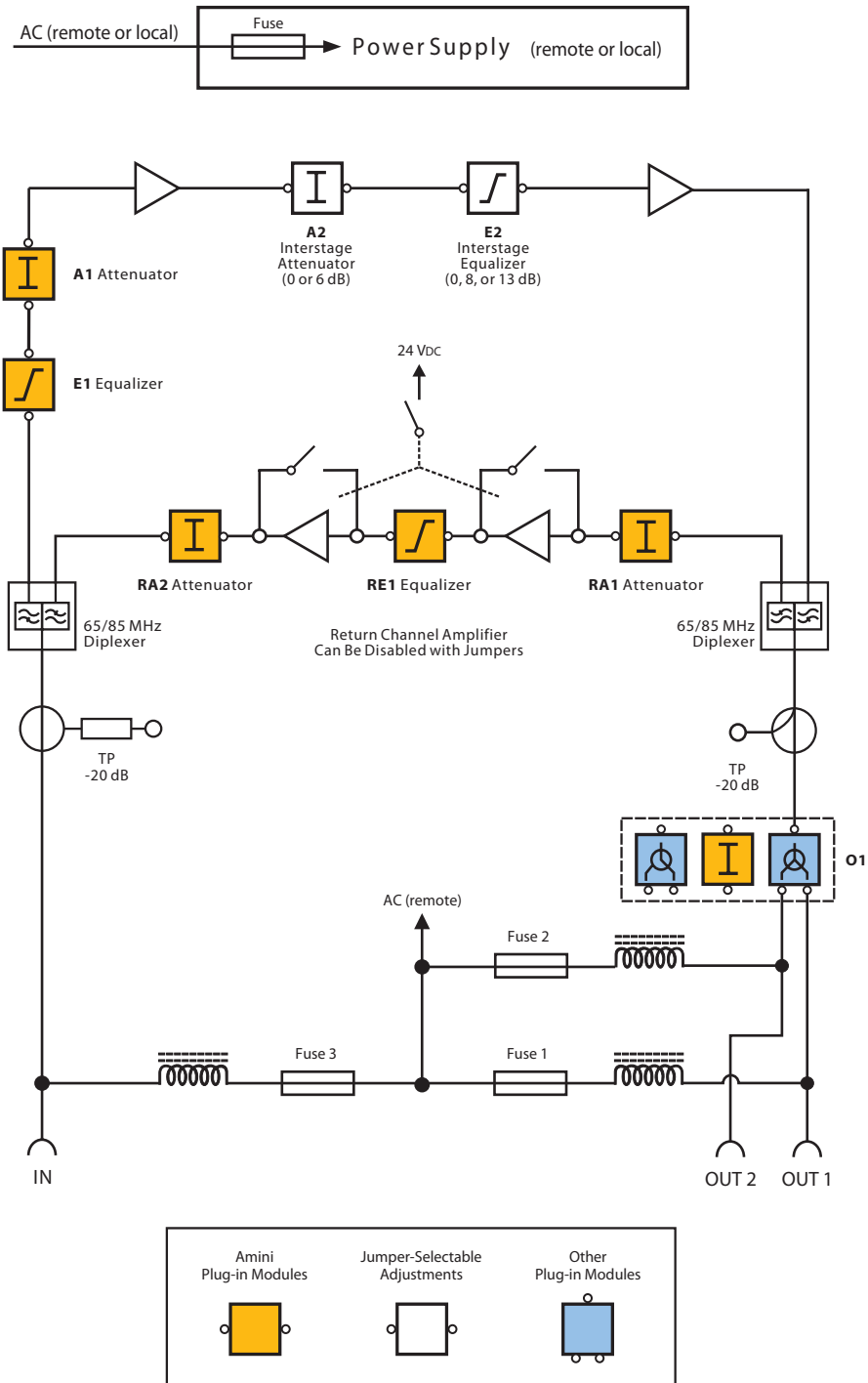

Flex Max222 Basic Distribution Amplifier Block Diagram

Specifications

General Specifications

Band Coverage	85 to 862 MHz, with ± 0.75 dB frequency response
Noise Figure	8.0 dB, typ.
Return Loss, excludes diplexer crossover range	> 18 dB at 40 MHz (-1.5 dB/octave up to 862 MHz)
Gain, includes diplexers	Standard: 37 dB \pm 1 dB; High: 41 dB \pm 1 dB
Impedance	75 Ohm
Testpoints	Bidirectional TP: -20 dB forward I/P; -18.5 dB return O/P Directional coupler TP: -20 dB forward output

Performance Specifications (output levels required to achieve ≤ -60 dBc CTB and CSO)

Std. Gain, Max. Efficiency Model @ Full 37 dB Gain (Note 1)	110 dB μ V (50 dBmV)
Std. Gain, Max. Efficiency Model @ 31 dB Gain (Note 2)	107 dB μ V (47 dBmV)
Standard Gain Models @ Full 37 dB Gain (Note 1)	112 dB μ V (52 dBmV)
Standard Gain Models @ 31 dB Gain (Note 2)	109 dB μ V (49 dBmV)
High Gain Models @ Full 41 dB Gain (Note 1)	115 dB μ V (55 dBmV)
High Gain Models @ 35 dB Gain (Note 2)	112 dB μ V (52 dBmV)

Active Return Channel Amplifier (can be disabled with jumpers)

Band Coverage	5 to 65 MHz, with ± 0.75 dB frequency response
Noise Figure	7.0 dB, typ.; 8.0 dB, max.
Return Loss	> 18 dB
Station Gain, single output, with diplexers & 0 dB Aminis	
Active	24 dB (with both gain stages) or 11 dB (with one gain stage)
Passive	-3.8 dB
Output Level, IM2 ≥ 60 dB	110 dB μ V (50 dBmV)

Powering Specifications

Power Supply Options	Remote: 28 to 65 VAC, 47 to 63 Hz; Local: 90 to 250 VAC, 47 to 63 Hz
Power Consumption, typ., 85% efficiency	Standard gain, max. efficiency model: 12 W Standard gain models: 16 W High gain models: 18 W
Power Passing Capability	
RF Input and Output	3 A or 6 A, max. (see <i>Ordering Information</i>)
HUM, at max. remote feeding	< -60 dBc

Plug-In Modules

Input and Return Path Attenuators	Amini: 0 to 20 dB, in 1 dB increments
Input and Return Path Equalizers	Amini: 0 to 16 dB, in 1 dB increments
Output Configuration Modules	Amini 0 dB: single output Splitter: 4/4 dB symmetrical dual output (P/N 2501157) TAPs: 8/2.6 dB asymmetrical dual output (P/N 2501158) 12/1.8 dB asymmetrical dual output (P/N 2501159)

Physical and Environmental Specifications

Dimensions (W x H x D)	221 x 92 x 187 mm (8.8 x 3.9 x 7.5 in.)
Weight, approx.	2.0 kg (4.5 lbs)
Connectors (see <i>Ordering Information</i> for RF input/output port connectors)	
RF Testpoints	F-type, male
Local Power Supply	PG9
Operating Temperature Range	-40 to 60°C (-40 to 140°F), without permanent failure -20 to 60°C (-4 to 140°F), guaranteed
Storage Temperature Range	-40 to 70°C (-40 to 160°F)
Protection According to IEC 529	IP55, IP67

Notes:

1. According to EN 50083-3, 41 CENELEC channel loading, and with 8 dB slope and 0 dB interstage attenuation.
2. According to EN 50083-3, 41 CENELEC channel loading, and with 8 dB slope and 6 dB interstage attenuation.

Specifications subject to change without notice

Ordering Information

				1	2	3	4	5	6		7	8	9	10	11		12	
F	M	2	2	2	x	B	6	A	x	x	-	x	x	M	N	x	-	x

1 Power Passing	
- 3A	a
P 6A	b
a) Select "A", "N", or "S" in #6 block, Fuse .	
b) Select "P" #6 block, Fuse .	

2 Platform	
B Basic 2-output	

3 Frequency Split	
6 65/85MHz	

4 Return Channel Amplifier	
A Active return	

5 Power Supply	
2 Local powering (90–250VAC)	a
6 Remote powering (28–65VAC)	b
a) Select "N" in #6 block, Fuse ; "-" in #1 block, Power Passing ; "5" in #11 block, Protection .	
b) Select "A", "P", or "S" in #6 block, Fuse ; "6" in #11 block, Protection .	

6 Fuse	
A 4A fuse	a
P 10A fuse	b
N No fuse	c
S Shorting bar	
a) Must select "-" in #1 block, Power Passing .	
b) Must select "P" in #1 block, Power Passing .	
c) In case of local powering. Select "2" in #5 block, Power Supply .	

7 Platform Output	
H High gain (41 dB)	a
M Standard gain (37 dB), maximum efficiency	b
S Standard gain (37 dB)	c
a) 18 W power consumption. Can select "-" or "P" in #1 block, Power Passing .	
b) 12 W power consumption. Must select "P" in #1 block, Power Passing .	
c) 16 W power consumption. Can select "-" or "P" in #1 block, Power Passing .	

8 RF Adapter	
3 3.5/12 type	
5 5/8-inch	
F F-type	
I IEC type	

9 RF Testpoint Connector	
M F-type, male	

10 Status Monitoring	
N No status monitoring	

11 Protection	
5 IP55	
6 IP67	

12 Country Deviations (defines mains plug and country certifications)	
N No power cord (remote powering)	a
E Europe	b
a) Select "6" in #5 block, Power Supply .	
b) Select "2" in #5 block, Power Supply .	

Americas Headquarters
 60 Decibel Road • State College • Pennsylvania • 16801 • USA
 T: 1-814-238-2461 T: 1-800-233-2267 F: 1-814-238-4065

EuroPacific Headquarters
 Transistorstraat 44-V • 1322 CG Almere • The Netherlands
 T: 31-36-546 1111 F: 31-36-536 4255

Flex Max is a trademark and the C-COR logo is a registered trademark of C-COR Incorporated.
 Copyright © 2007 C-COR Incorporated. All rights reserved.

