



Dual Return Path Receivers

C-COR® CHP Max5000

Converged Headend Platform

- Resilient operation for VoIP and business data applications
- Integrated optical path and RF switching option
- High RF output eliminates external amplifiers
- High density system with up to 20 ports per 2RU chassis and up to 400 ports per 40RU rack
- Simplified installation and control with graphical user interface
- Universal management through Craft interface and SNMP with HMS



The ARRIS C-COR CHP Max5000 Dual Return Path Receivers are an integral part of return path system applications and are available as either a standard or redundant module. Advanced two-way services—such as video on demand, high speed Internet access, and telephony—require superior return path delivery capacity and performance. The ARRIS CHP Max5000 headend optical platform can help you meet these demands. The CHP Max5000 standard Dual Return Path Receivers offer high RF output and high efficiency optical performance for excellent carrier-to-noise performance, and the redundant model allows either stand-alone or redundancy operations.

The CHP Max5000 Dual Return Path Receivers accept two optical inputs in a single-width CHP Max5000 module. Two receivers in one housing means you can pack up to 20 receivers in one 2RU CHP Max5000 chassis (up to 400 in one standard 40RU rack) to relieve the pressure on precious headend space as you expand offering of advanced two-way services.

The redundant modules enable optical path and hardware protection for mission critical applications such as VoIP and business data provisioning. The integral optical and RF switches will alternate between diverse paths when an optical path or module hardware fault is detected. Switch time is less than 50 milliseconds to ensure telephony call hold time. Module pairs can reside in the same CHP Max5000 chassis or in separate chassis up to 6 meters (20 feet) apart through interconnection with the RCL2 cable.

The CHP Max5000 Dual Return Path Receivers are hot-swappable. Monitoring, configuration control, and firmware download are provided through a Craft graphical user interface (GUI) locally using a Craft Management Module (CMM). Both local and remote IP access of the Craft GUI, firmware download, and remote SNMP HMS interface are achieved using the System Management Module (SMM).

Features

- Redundant version integrates optical path and RF switching on same module
- Redundant pair module option can reside in same chassis or separate chassis
- Up to 20 separate receiver channels per chassis and 400 receivers per rack for high density and reduced cooling and power costs
- 5 to 200 MHz transmission bandpass
- Front-panel RF testpoint for convenient monitoring
- RF output level adjustment per channel via front panel control, local or remote IP access to Craft GUI, or SNMP
- Downloadable firmware for module upgrades

CHP Max5000 Headend Platform Diagram

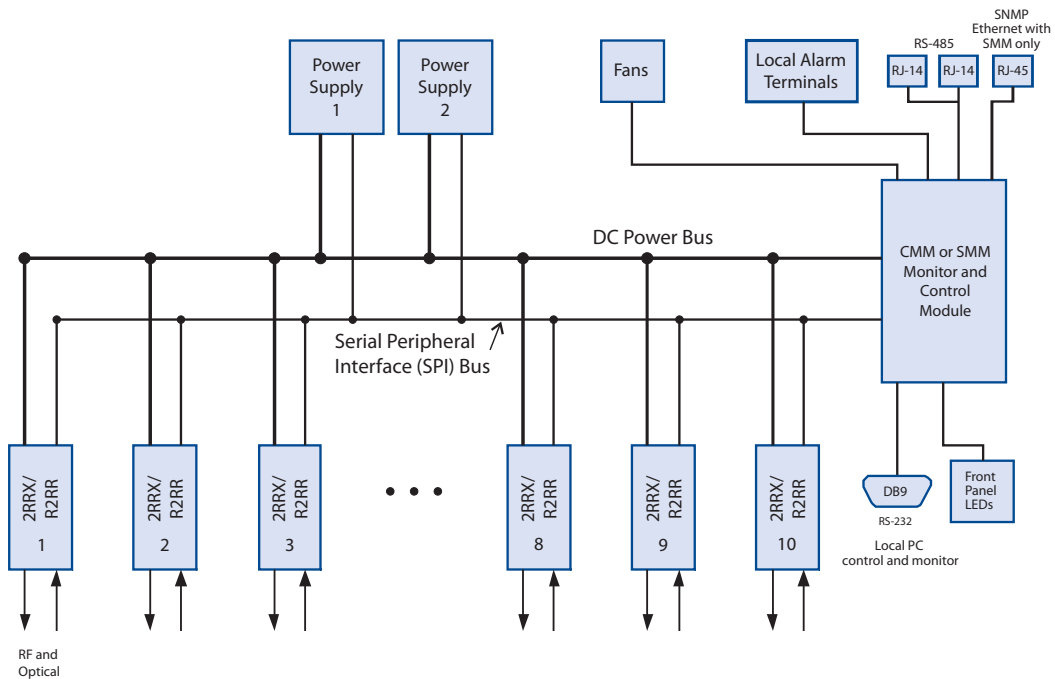

CHP-2RRX-S and CHP-R2RR-S Specifications

	CHP-2RRX-S	CHP-R2RR-S
Optical Specifications		
Input Wavelength Range	1200 to 1620nm	1200 to 1620nm
Optical Input Range	-20 to 3dBm	-13 to 3dBm
RF Specifications		
RF Output Bandwidth	5 to 200MHz	5 to 200MHz
RF Output Power Level, min., per channel (Notes 1 and 2)	40dBmV, with -9 dBm input and 7% OMI from return TX	38dBmV, with -13 dBm input and 7% OMI from return TX
Frequency Response Flatness, peak-to-valley	±0.75dB	±0.75dB
Frequency Response Slope, highest frequency to lowest	±1.0dB	±1.0dB
RF Gain Adjustment Range (Note 3)	0 to -31.5 in 0.5dB steps	0 to -31.5 in 0.5dB steps
Return Loss, min.	16dB	16dB
RF Testpoint	-20 ± 0.5dB	-20 ± 0.5dB
Performance Specifications		
Equivalent Noise Input, max.	7pA/Hz ^{0.5}	7pA/Hz ^{0.5}
Second Order Distortion, max. (Notes 1 and 4)	-60dBc	—
Third Order Distortion, max. (Notes 1 and 4)	-60dBc	—
Bit Error Rate (link) (Note 5)	for link: < 1 x 10 ⁻⁸	See Note 6
Noise-Power Ratio (NPR)/Dynamic Range (link) (Note 7)	40/15dB	41/15dB
Channel-to-Channel Isolation, 5 to 200MHz	> 65dB	> 65dB
Power Consumption	7W	16W
Mechanical Specifications		
Dimensions (W x H x D)	1.25 x 3.44 x 18.5 in. (3.18 x 8.74 x 46.99 cm)	1.25 x 3.44 x 18.5 in. (3.18 x 8.74 x 46.99 cm)
Environmental Specifications		
Operational Temperature Range	32 to 122°F (0 to 50°C)	32 to 122°F (0 to 50°C)

Notes:

1. Measured with CW carriers.
2. RF output for CHP-2RRX-S is based on 23 16-QAM channels with an optical input of -9 dBm at 7% OMI. RF output for CHP-R2RR-S is based on 23 16-QAM channels with an optical input of -13 dBm at 7% OMI. Tested with a C-COR NRT-WB2HP return transmitter with 8dBmV/channel at transmitter testpoint.
3. The attenuator for each channel in the CHP-R2RR module may be adjusted in 0.5dB steps from 0 to 31.5dB. However, the RF output level stability specification may not be met at the attenuator setting of 30.5, 31.0, or 31.5dB over the operating temperature range.
4. Two laser test, 40% OMI, 0.5mW per laser.
5. When tested with 16-QAM modulation and a C-COR NRT-WB2HP return transmitter with 8 dBmV/channel at transmitter testpoint over an operational input range of -9 to 0dBm optical input. The CHP Max5000 receiver should have no contribution to link BER.
6. BER dynamic range of >40dB with a BER of < 1 x 10⁻⁶.
7. No contribution to link NPR when tested with a C-COR NRT-WB2HP return transmitter over an operational input range of -9 to 0dB.

Specifications subject to change without notice

Dual Return Path Receivers C-COR® CHP Max5000

Ordering Information

Standard Dual Return Path Receiver

				1						2
C	H	P	-	2	R	R	X	-	S	

1	Number of Receivers
2	Dual receivers

2	Connector Type
S	SC/APC

Redundant Dual Return Path Receiver

				1	2					3
C	H	P	-	R	2	R	R	-	S	

1	Type of Receivers
R	Redundant receivers

2	Number of Receivers
2	Dual receivers

3	Connector Type
S	SC/APC

Note: Requires two modules for redundant operation. Must use CHP-RCL-xx cable interconnected between modules for redundant operation.

Redundancy Cable

									1	2
C	H	P	-	R	C	L	2	-	x	x

1-2	Length of Redundancy Cable	
E0	Two inch redundancy cable	a
01	One foot redundancy cable	
05	Five foot redundancy cable	
10	Ten foot redundancy cable	
20	Twenty foot redundancy cable	
<i>a) European installations must only use the CHP-RCL2-E0 redundant cable</i>		



The capabilities, system requirements and/or compatibility with third-party products described herein are subject to change without notice. ARRIS, the ARRIS logo, C3™, C4™, CableEdge®, Cadant®, C-COR®, CHP Max®, Cornerstone®, CXM™, D5™, Digicon®, Flex Max®, Keystone™, MONARCH®, n5™, nABLE™, NSM®, nVision®, PLEXIS®, Regal®, ServAssure™, TeleWire Supply®, Touchstone®, VoiceAssure™, and WorkAssure™ are all trademarks of ARRIS Group, Inc. Other trademarks and trade names may be used in this document to refer to either the entities claiming the marks and the names of their products. ARRIS disclaims proprietary interest in the marks and names of others. © Copyright 2008 ARRIS Group, Inc. All rights reserved. Reproduction in any manner whatsoever without the express written permission of ARRIS Group, Inc., is strictly forbidden. For more information, contact ARRIS.

CHPRRX-D-0208

