

# 1 GHz 3-Input Forward Path RF Amplifier

## GAMP3

### CHP Max5000

#### Converged Headend Platform



- **1 GHz technology**
- **One broadcast and two narrowcast RF inputs**
- **Broadcast and narrowcast gains are GUI adjustable**
- **Tunable equalization for broadcast input**
- **Reduced signal combining and cable wiring complexity**
- **Low profile footprint allows 200 amplifiers in a standard rack**
- **Universal local or remote management through Craft interface and SNMP with HMS**

The CHP Max5000 1 GHz 3-Input Forward Path RF Amplifier is a hot-swappable module that can be used as a key system component in a headend or hub environment to provide RF signal amplification and narrowcast layering. The innovative 3 RF inputs, 1 broadcast and 2 narrowcast, support layered services such as SDV, VOD, and HSD. This amplifier is designed to provide system operators a low cost way to overcome network losses, with minimal degradation to system performance, caused by combining and splitting networks that are typically found in HFC headends/hubs.

Up to 10 CHP Max5000 amplifiers can reside in the 2RU CHP Max5000 chassis, with one broadcast RF input, two narrowcast RF inputs, and one RF output connector access on the rear panel. A front panel RF testpoint provides a sample of the RF output, reduced by 20 dB.

#### Features

- 1 GHz single output with forward passband of 50 to 1002 MHz
- The maximum gain for the broadcast port is 20 dB, the narrowcast ports are 10 dB
- In-service tunable equalization within the Craft GUI monitoring system reduces setup time and increases control
- 1 broadcast input and 2 narrowcast inputs support layered narrowcast service implementation, such as SDV, VOD, and HSD
- Superior CNR and distortion performance
- Gain adjustable by 6 dB in 0.25 dB steps via Craft GUI or SNMP
- Superior reverse port-to-port isolation enables the combination of multiple narrowcast sources to reduce external signal combining and simplify cable wiring.
- Front-panel RF output testpoint for convenient monitoring
- Low profile footprint allows 10 amplifiers in a shelf

**Application**

In this layered narrowcasting configuration, a single broadcast signal combines with a narrowcast signal and 2 additional narrowcast signals are split into 6 CHP Max5000 3-input RF Amplifiers. The 3 RF inputs, 1 broadcast and 2 narrowcast, support layered services such as SDV, VOD, and HSD. The amplifiers providing signal to the network are a low cost way to overcome network losses, with minimal degradation to system performance, caused by combining and splitting networks that are typically found in HFC headends/hubs.

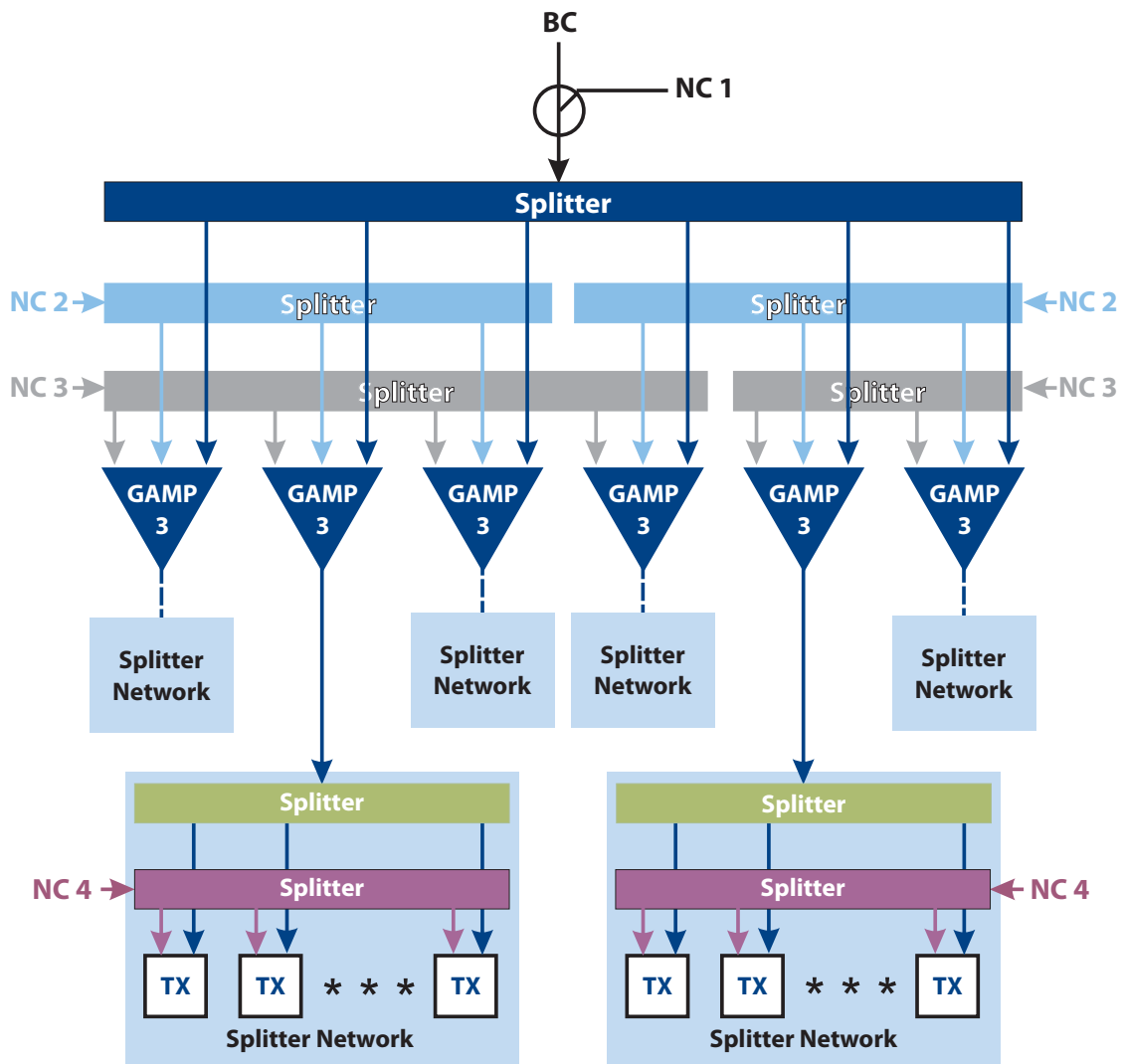

**Layered Narrowcasting Configuration**

## Specifications

### RF

Bandwidth, MHz	
BC Port	50 to 1002
NC1 and NC2 Ports	400 to 1002
Response Flatness, typ., dB	
BC, NC1, NC2	±0.5
Response Tilt, max., dB	
BC Port at nominal tilt, NC1, NC2	±0.5
Return Loss for all four ports, min., dB	16
Gain Control Range, dB	
BC Port (Note 1)	14 to 20
NC1 and NC2 Ports (Note 1)	-16 to -10dB gain difference relative to BC port
Adjustable EQ Tilt (50 to 1002MHz, dB)	0 to 3 in 0.5 dB steps, BC port only
RF Output Testpoint (Note 2), dB	-20 ± 0.75
Port-to-port Isolation, min., dB	
BC to NC1, BC to NC2	50
NC1 to BC, NC2 to BC	42 at -10dB gain difference
NC1 to BC, NC2 to BC	48 at -16dB gain difference
NC1 to NC2, NC2 to NC1	50
Back Isolation from the Output port to any input port	60
Noise Figure for Broadcast Port, typ., dB	8 at 0dB tilt over the entire gain control range
Rated Input Level	15 dBmV/channel maximum for analog loading at BC port 25 dBmV/QAM channel maximum for digital loading at NC1 and NC2 ports

### Performance Characteristic (Note 3)

Composite Triple Beat (CTB), dBc	-85
Composite Second Order (CSO), dBc	-74
CIN, dBc	-70
XMOD, dBc	-79

### Powering

Power Consumption, max., W	12.5
----------------------------	------

### Mechanical

RF Connectors	F-type
Dimensions (W x H x D) (Note 4), in. (cm)	1.25 x 3.4 x 18.5 (3.2 x 8.7 x 47.0)
Weight, lbs (kg)	2.75 (1.24)

### Environmental

Operating Temperature (Note 5), °C (°F)	0 to 50 (32 to 122)
Storage Temperature, °C (°F)	-40 to 70 (-40 to 158)
Operating Humidity, nonconducting, max.	85%
Storage Humidity, noncondensing, max.	95%

#### Notes:

1. Default gain is 17 dB for BC port and is 4 dB for NC1 and NC2 ports.
2. Relative to broadcast port.
3. Specifications obtained using 79 NTSC CW channels (50 to 550MHz) with an input of 15dBmV/channel applied to the input of the BC port, and full digital loading (550 to 1002MHz) with 25dBmV/channel maximum applied to one of the NC ports. At the output of the CHP-GAMP3, the level per digital channel is 6dB lower than the analog channels. The gain for the BC port is 20dB and the NC gain difference is -16dB (NC gain is 4dB). The tilt is 0dB.
4. Includes handles and connectors.
5. Temperature measured at amplifier module's air inlet.

Specifications subject to change without notice

**Functional Block Diagram**

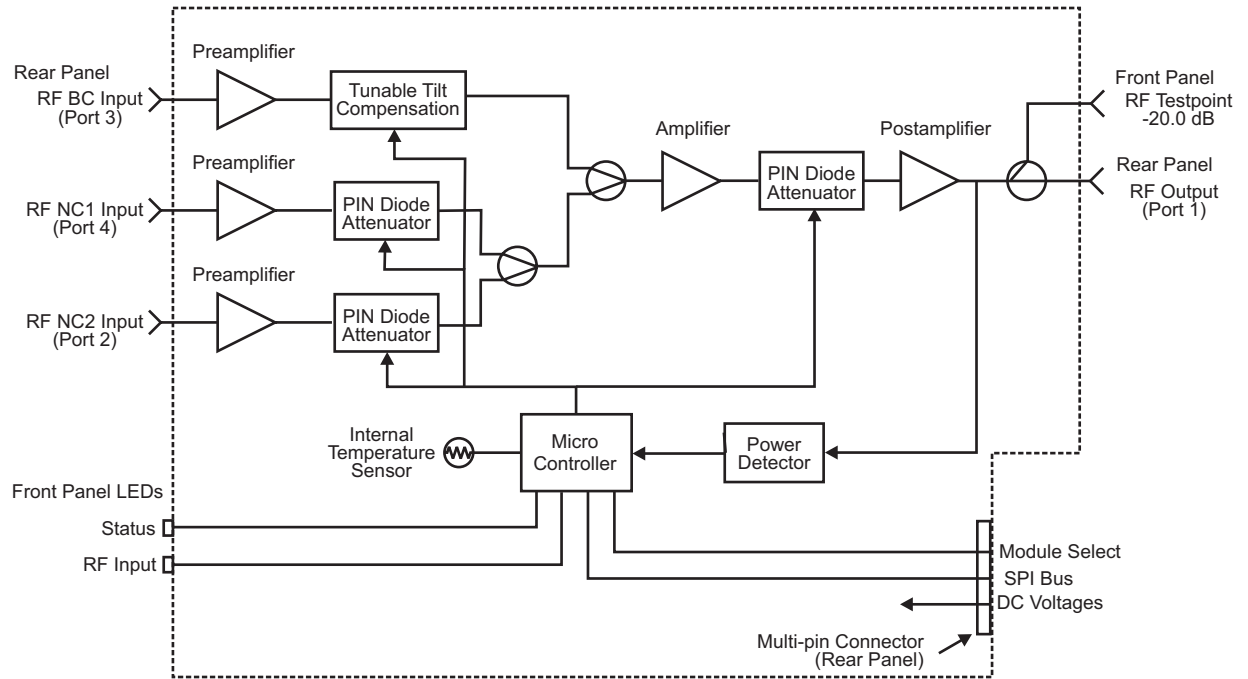

**Ordering Information**

				<b>1</b>	<b>2</b>	<b>3</b>	<b>4</b>	<b>5</b>
<b>C</b>	<b>H</b>	<b>P</b>	<b>-</b>	<b>G</b>	<b>A</b>	<b>M</b>	<b>P</b>	<b>3</b>

<b>1-5</b>	<b>Type of Module</b>
GAMP3	1 GHz 3-input forward path RF amplifier

Contact your C-COR sales professional to discuss how our exciting new 1 GHz products can add value to your network.

**Americas Headquarters**

60 Decibel Road • State College • Pennsylvania • 16801 • USA  
 T: 1-814-238-2461 T: 1-800-233-2267 F: 1-814-238-4065

**EuroPacific Headquarters**

Transistorstraat 44-V • 1322 CG Almere • The Netherlands  
 T: 31-36-546 1111 F: 31-36-536 4255

CHP Max is a trademark and the C-COR logo is a registered trademark of C-COR Incorporated.  
 Copyright © 2005 C-COR Incorporated. All rights reserved.



www.c-cor.com